

Model 300 Sky Sentry Fume Extractor

Model # SS-300-SKY Product Specifications

BASE UNIT DIMENSIONS

13" Length
13" Width, *Not Including Wall-Mounting Brackets*
16.5" Height

ARM DIMENSIONS

4" Dia., 32" Long Fire-Retardant Flex Hose and 15" L
Stainless Steel Ducting (7" Dia. Round Hood)

CABINET MATERIAL

16 ga. carbon steel with polyester
epoxy coating on all surfaces

WEIGHT

Approx. 60 lbs. - 70 lbs.

AIR VOLUME

Variable Speed Control Standard on 115V
350 CFM High, Down to 50 CFM Low
On/Off Toggle Switch Standard on 220V

ELECTRICAL

115/1/60, 2 amps
220/1/50, 0.75 amps
8' grounded power cord with NEMA 5-15P Plug

SOUND LEVEL

61 to 66 dba (Blower Speed: Low to High)

FILTRATION

Depending on the Application:

- HEPA [up to 99.97% efficient on particles 0.3 microns and larger]
- ASHRAE [up to 95% efficient on particles 0.5 microns and larger]
- ACTIVATED CARBON
- SPECIALTY-BLENDED FILTER MEDIA [i.e. Acid Gas, Mercury, Aldehyde, Ammonia]

WARRANTY

Limited two-year warranty from date of shipment on
defects due to materials or workmanship.
PATENT #5,843,197

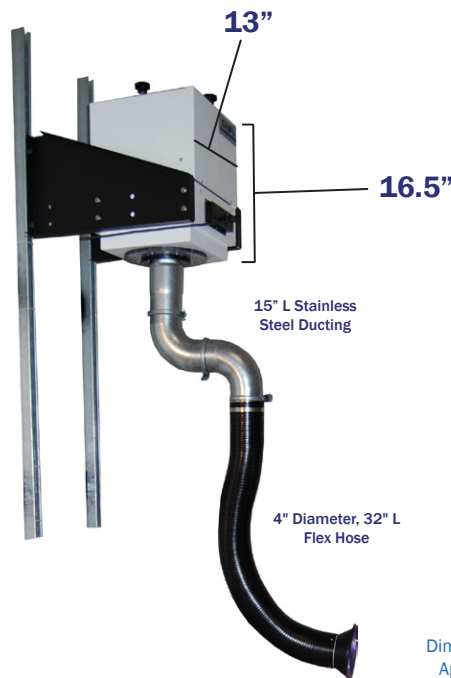

Dimensions are
Approximate



Product Features

- Variable Speed Remote Controller *Included*
- Wall-Mounting Brackets *Included*
- Quiet Operation
- Reliable, Low Maintenance Operation
- Low Power Consumption
- Simple, Quick "No Tool" Filter Change
- Long Filter Life
- Optional Magnehelic Gage
- Optional Hour Counter

The **Sky Sentry** is a uniquely engineered wall-mounted fume extractor. This source-capture system features a free-hanging, self-supportive and flame-retardant flex arm that can easily be maneuvered by the operator to their desired location. When mounted to the wall, the arm features a 62.5" swivel radius. In limited space environments, this unit frees up valuable benchtop and floor space.

Typical applications for this system include: welding fume extraction, solder fume control, brazing, particulate, removal of organic vapors, solvent and epoxy fumes, chemical fumes, light grinding, and various other industrial processes where a wall-mounted fume extractor is needed.

Depending on the application, several filter combinations can be utilized. Typical filtration media include: HEPA [up to 99.97% efficient on particles 0.3 microns and larger], ASHRAE [up to 95% efficient on particles 0.5 microns and larger], Activated Carbon, and specialty-blended filtration media [i.e. Acid Gas, Mercury, Aldehyde, Ammonia].

The **Sky Sentry Fume Extractor** combines quiet operation, energy-efficient technology, and a unique mounting option that creates an effective solution for many applications that require fume and particulate removal. A smaller model [SS-300-SKY] and larger model [SS-400-SKY] are also available.



1.800.799.4609
www.sentryair.com
sales@sentryair.com

