

# 100 Series Solder Fume Extractors

Sentry Air Systems, Inc.



1.800.799.4609

[www.sentryair.com](http://www.sentryair.com)

## 100 Series Solder Fume Extractors



### Stainless Steel Solder Sentry [Model SS-100-SS-ST]

The Stainless Steel Solder Sentry is an ESD-Safe solder fume extraction unit. It is constructed for stationary, benchtop applications that require the capture and filtration of airborne contaminants at the work surface. The unit has been proven to work well for solder fumes and smoke extraction.

Up to 80 CFM / HEPA or ASHRAE Filtration  
Product Specifications: Page 2



### Stainless Steel Floor Sentry [Model SS-100-FS-ST]

The Stainless Steel Floor Sentry is an ESD-Safe fume extractor that was engineered to free up much needed benchtop work space. This unit is equipped with a self-supportive, anti-static flex hose that can be easily maneuvered by the operator while the base of the unit either sits on the floor or on the benchtop.

Up to 80 CFM / HEPA or ASHRAE Filtration  
Product Specifications: Page 3



### Stainless Steel Winged Sentry [Model SS-100-WS-ST]

The Stainless Steel Solder Sentry is an ESD-Safe solder fume extraction unit. It is constructed for stationary, benchtop applications that require the capture and filtration of airborne contaminants at the work surface. This unit is equipped with infinitely adjustable "wing flaps" and the optional transparent hinged lid completes a nearly perfect enclosure.

Up to 80 CFM / HEPA or ASHRAE Filtration  
Product Specifications: Page 4



### Solder Sentry [Model SS-100-SS]

The Solder Sentry is built specifically for stationary, benchtop soldering applications where airborne solder fumes need to be captured and purified at the work surface. The Solder Sentry is a compact source capture solder fume extractor that has a horizontal airflow pattern.

Up to 80 CFM / HEPA or ASHRAE Filtration  
Product Specifications: Page 5



### Solder Pot Sentry [Model SS-100-PS]

The Solder Pot Sentry is a benchtop solder fume extractor that is designed for slightly elevated operations such as solder pot applications. The height stand can be adjusted based on the need of the operator.

Up to 80 CFM / HEPA or ASHRAE Filtration  
Product Specifications: Page 6

The 100 Series is Sentry Air Systems' smallest line of benchtop and portable air purification units. With a combination of energy-efficient fans and high-quality filtration media, these units are best equipped for applications requiring the removal of solder fumes & particulate. Typically, 100 series units are equipped with either HEPA or ASHRAE filters. Sentry Air's HEPA filters are up to 99.97% efficient on particles 0.3 microns and larger, while ASHRAE filters are up to 95% efficient on particles 0.5 microns and larger. Sentry Air Systems' HEPA and ASHRAE filters are unique because of their flame-retardant composition.

# Stainless Steel Solder Sentry

## Model # SS-100-SS-ST

## ESD-SAFE

### Product Specifications

#### OVERALL DIMENSIONS

6.25" Length  
8" Width  
8" Height

#### CABINET MATERIAL

16 ga. Stainless Steel

#### WEIGHT

Approx. 8 lbs.

#### AIR VOLUME

Up to 80 CFM. *Varies with filter media.*

#### ELECTRICAL

115/1/60, Approx. 0.3 Amps  
220/1/50, Approx. 0.2 amps  
8' grounded power cord  
with NEMA 5-15P Plug

#### SOUND LEVEL

62 DBA at 3'

#### FILTRATION

**HEPA FILTRATION-**  
99.97% efficient on particles 0.3 microns and larger.

**ASHRAE FILTRATION-**  
95% efficient on particles 0.5 microns and larger.

*These filters are composed of flame-retardant materials.*

#### WARRANTY

Limited two-year warranty from date of shipment on defects due to materials or workmanship.  
PATENT #5,843,197



Dimensions are Approximate

### Product Features

- ESD-Safe
- Highly Portable and Lightweight
- Reliable, Low Maintenance Operation
- Quiet Operation
- Simple, Quick "No Tool" Filter Change
- Long Filter Life
- Sturdy Construction
- Attractive Appearance
- Optional Velometer

The **Stainless Steel Solder Sentry** is an ESD-Safe solder fume extraction unit. It is constructed for stationary, benchtop applications that require the capture and filtration of airborne contaminants at the work surface. This has been proven to work well for solder fumes and smoke extraction.

This system is equipped with an energy-efficient fan and high-quality filtration media: typically HEPA or ASHRAE filtration. These filters are unique in that the primary materials have been constructed from fire-retardant products. HEPA filtration is up to 99.97% efficient on particles 0.3 microns and larger, while ASHRAE filtration is up to 95% on particles 0.5 microns and larger.

The Stainless Steel Solder Sentry offers an effective, quiet & economical solution for many benchtop soldering operations which require ESD-safe fume extraction. All of Sentry Air's products are proudly manufactured in the United States and are backed by our two-year limited warranty on parts and labor.



1.800.799.4609  
www.sentryair.com  
sales@sentryair.com





# Stainless Steel Floor Sentry

## Model # SS-100-FS-ST

## ESD-SAFE

### Product Specifications

#### BASE UNIT DIMENSIONS

8" Length  
8" Width  
8.25" Height

#### ARM DIMENSIONS

3" Round x 43" Long (6" Wide Hood),  
Anti-Static Material

#### CABINET MATERIAL

16 ga. Stainless Steel

#### WEIGHT

Approx. 8 lbs.

#### AIR VOLUME

Up to 80 CFM. *Varies with filter media.*

#### ELECTRICAL

115/1/60, Approx. 0.3 Amps  
220/1/50, Approx. 0.2 amps  
8' grounded power cord  
with NEMA 5-15P Plug

#### SOUND LEVEL

62 DBA at 3'

#### FILTRATION

**HEPA FILTRATION-**  
99.97% efficient on particles 0.3 microns and larger.

**ASHRAE FILTRATION-**  
95% efficient on particles 0.5 microns and larger.

*These filters are composed of flame-retardant materials.*

#### WARRANTY

Limited two-year warranty from date of shipment on defects due to materials or workmanship.

PATENT #5,843,197



Dimensions are Approximate

### Product Features

- ESD-Safe Base Unit & Anti-Static Flex Hose
- Highly Portable and Lightweight
- Reliable, Low Maintenance Operation
- Quiet Operation
- Simple, Quick "No Tool" Filter Change
- Long Filter Life
- Sturdy Construction
- Attractive Appearance
- Optional Velometer

The **Stainless Steel Floor Sentry** is an ESD-Safe fume extractor that was engineered to free up much needed benchtop workspace. This unit is equipped with a self-supportive, anti-static flex hose that can be easily maneuvered by the operator while the base of the unit either sits on the floor or on the benchtop. The self-supportive hose allows the operator to comfortably adjust the hose to the optimal source-capture position.

This system is equipped with an energy-efficient fan and high-quality filtration media: typically HEPA or ASHRAE filtration. These filters are unique in that the primary materials have been constructed from fire-retardant products. HEPA filtration is up to 99.97% efficient on particles 0.3 microns and larger, while ASHRAE filtration is up to 95% efficient on particles 0.5 microns and larger.

The Stainless Steel Floor Sentry is an effective, quiet & economical solution for many soldering operations which require fume extraction. All of Sentry Air's products are proudly manufactured in the United States and are backed by our two-year limited warranty on parts and labor.



1.800.799.4609  
www.sentryair.com  
sales@sentryair.com



# Stainless Steel Winged Sentry

## Model # SS-100-WS-ST

## ESD-SAFE

### Product Specifications

#### OVERALL DIMENSIONS

6.25" Length  
8" Width  
8" Height

#### CABINET MATERIAL

16 ga. Stainless Steel

#### WEIGHT

Approx. 8 lbs.

#### AIR VOLUME

Up to 80 CFM. *Varies with filter media.*

#### ELECTRICAL

115/1/60, Approx. 0.3 Amps  
220/1/50, Approx. 0.2 amps  
8' grounded power cord  
with NEMA 5-15P Plug

#### SOUND LEVEL

62 DBA at 3'

#### FILTRATION

**HEPA FILTRATION-**  
99.97% efficient on particles 0.3 microns and larger.

**ASHRAE FILTRATION-**  
95% efficient on particles 0.5 microns and larger.

*These filters are composed of flame-retardant materials.*

#### WARRANTY

Limited two-year warranty from date of shipment on defects due to materials or workmanship.  
PATENT #5,843,197

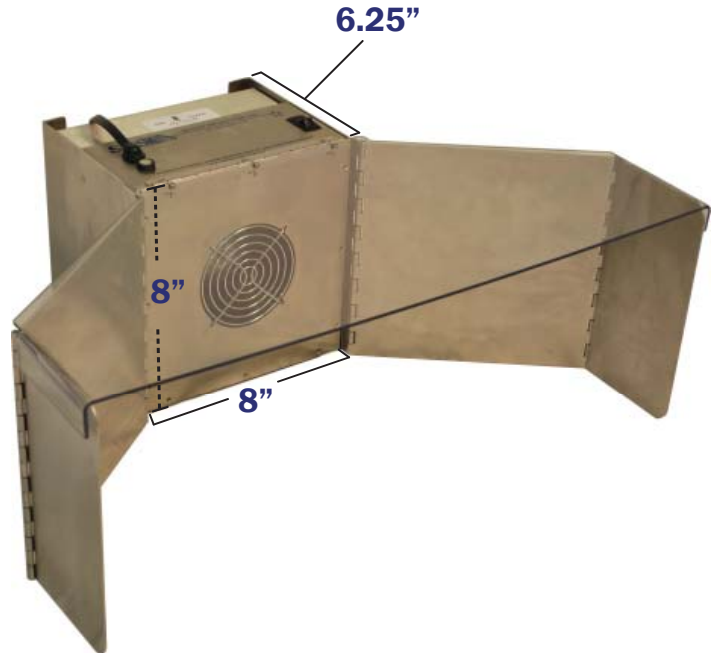

Shown with Optional Lid  
Dimensions are Approximate

### Product Features

- ESD-Safe
- Adjustable Wing Flaps
- Highly Portable and Lightweight
- Reliable, Low Maintenance Operation
- Quiet Operation
- Simple, Quick "No Tool" Filter Change
- Sturdy Construction
- Long Filter Life
- Optional Hinged, Clear Acrylic Lid

The **Stainless Steel Winged Sentry** is an ESD-Safe solder fume extraction unit. It is constructed for stationary, benchtop applications that require the capture and filtration of airborne contaminants at the work surface. This unit is equipped with infinitely adjustable "wing flaps" and the optional transparent hinged lid completes a nearly perfect enclosure.

This system is equipped with an energy-efficient fan and high-quality filtration media: typically HEPA or ASHRAE filtration. These filters are unique in that the primary materials have been constructed from fire-retardant products. HEPA filtration is up to 99.97% efficient on particles 0.3 microns and larger, while ASHRAE filtration is up to 95% on particles 0.5 microns and larger.

The Stainless Steel Winged Sentry offers an effective, quiet & economical solution for many benchtop soldering operations which require ESD-safe fume extraction. All of Sentry Air's products are proudly manufactured in the United States and are backed by our two-year limited warranty on parts and labor.



1.800.799.4609  
www.sentryair.com  
sales@sentryair.com



# Solder Sentry

## Model # SS-100-SS

### Product Specifications

#### OVERALL DIMENSIONS

8" Length

8" Width

8" Height

#### CABINET MATERIAL

16 ga. Carbon Steel with Polyester  
Epoxy Coating on Surface

#### WEIGHT

Approx. 8 lbs.

#### AIR VOLUME

Up to 80 CFM. *Varies with Filter Media.*

#### ELECTRICAL

115/1/60, Approx. 0.3 Amps

220/1/50, Approx. 0.2 amps

8' grounded power cord  
with NEMA 5-15P Plug

#### SOUND LEVEL

Approx. 62 DBA at 3'

#### FILTRATION

##### HEPA FILTRATION-

99.97% efficient on particles 0.3 microns and larger.

##### ASHRAE FILTRATION-

95% efficient on particles 0.5 microns and larger.

*These filters are composed of flame-retardant materials.*

#### WARRANTY

Limited two-year warranty from date of shipment on  
defects due to materials or workmanship.

PATENT #5,843,197



Dimensions are Approximate

### Product Features

- Highly Portable and Lightweight
- Quiet Operation
- Sturdy Construction
- Reliable, Low Maintenance Operation
- Attractive Appearance
- Optional Height Stand (up to 8.75" H)
- Long Filter Life
- Simple, Quick "No Tool" Filter Change
- Optional Velometer

The **Solder Sentry** is built specifically for stationary, benchtop soldering applications where airborne solder fumes need to be captured at the work surface. The Solder Sentry is a compact and quiet solder fume extractor that has a horizontal airflow pattern and captures fumes at the source.

This system is equipped with an energy-efficient fan and high-quality filtration media: typically HEPA or ASHRAE filtration. These filters are unique in that the primary materials have been constructed from fire-retardant products. HEPA filtration is up to 99.97% efficient on particles 0.3 microns and larger, while ASHRAE filtration is up to 95% on particles 0.5 microns and larger.

An optional adjustable height stand is available for elevated operations such as solder pot applications. The Solder Sentry offers an effective, quiet, and economical solution for many benchtop soldering operations which require fume extraction. All of Sentry Air's products are proudly manufactured in the United States and are backed by our two-year limited warranty on parts and labor.



1.800.799.4609  
[www.sentryair.com](http://www.sentryair.com)  
[sales@sentryair.com](mailto:sales@sentryair.com)



# Solder Pot Sentry

## Model # SS-100-PS

### Product Specifications

#### BASE UNIT DIMENSIONS

8" Length  
8" Width  
8" Height

#### HEIGHT STAND DIMENSIONS

8.5" L x 9.5" W x Adjustable up to 8.75" H

#### CABINET MATERIAL

16 ga. Carbon Steel with Polyester Epoxy Coating on Surface

#### WEIGHT

Approx. 8 lbs.

#### AIR VOLUME

Up to 80 CFM. *Varies with Filter Media.*

#### ELECTRICAL

115/1/60, Approx. 0.3 Amps  
220/1/50, Approx. 0.2 amps  
8' grounded power cord  
with NEMA 5-15P Plug

#### SOUND LEVEL

62 DBA at 3'

#### FILTRATION

**HEPA FILTRATION-**  
99.97% efficient on particles 0.3 microns and larger.

**ASHRAE FILTRATION-**  
95% efficient on particles 0.5 microns and larger.

*These filters are composed of flame-retardant materials.*

#### WARRANTY

Limited two-year warranty from date of shipment on defects due to materials or workmanship.

PATENT #5,843,197



Dimensions are Approximate

## Product Features

- Height Stand Included
- Quiet Operation
- Sturdy Construction
- Highly Portable and Lightweight
- Long Filter Life
- Attractive Appearance
- Reliable, Low Maintenance Operation
- Simple, Quick "No Tool" Filter Change
- Optional Velometer

The **Solder Pot Sentry** is a benchtop solder fume extractor that is designed for slightly elevated operations such as solder pot applications. The height stand can be adjusted based on the need of the operator.

This system is equipped with an energy-efficient fan and high-quality filtration media: typically HEPA or ASHRAE filtration. These filters are unique in that the primary materials have been constructed from fire-retardant products. HEPA filtration is up to 99.97% efficient on particles 0.3 microns and larger, while ASHRAE filtration is up to 95% on particles 0.5 microns and larger.

The Solder Pot Sentry offers an effective, quiet, and economical solution for many benchtop soldering operations which require fume extraction. All of Sentry Air's products are proudly manufactured in the United States and are backed by our two-year limited warranty on parts and labor.



1.800.799.4609  
www.sentryair.com  
sales@sentryair.com

