

Stainless Steel Winged Sentry w/ Lid

Model # SS-100-WSL-ST

ESD-SAFE

Product Specifications

OVERALL DIMENSIONS

6.25" Length
8" Width
8" Height

CABINET MATERIAL

18 ga. Stainless Steel

WEIGHT

Approx. 8 lbs.

AIR VOLUME

Up to 80 CFM. *Varies with filter media.*

ELECTRICAL

115/1/60, Approx. 0.3 Amps
220/1/50, Approx. 0.2 amps
8' grounded power cord
with NEMA 5-15P Plug

SOUND LEVEL

62 DBA at 3'

FILTRATION

HEPA FILTRATION-
99.97% efficient on particles 0.3 microns and larger.

ASHRAE FILTRATION-
95% efficient on particles 0.5 microns and larger.

These filters are composed of flame-retardant materials.

WARRANTY

Limited two-year warranty from date of shipment on defects due to materials or workmanship.
PATENT #5,843,197

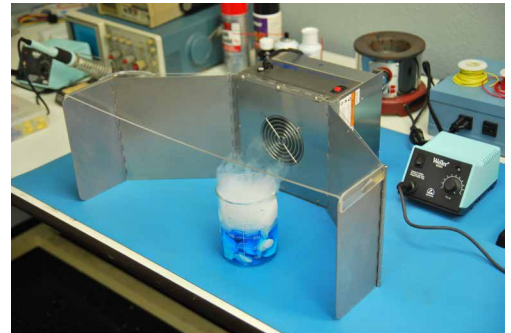
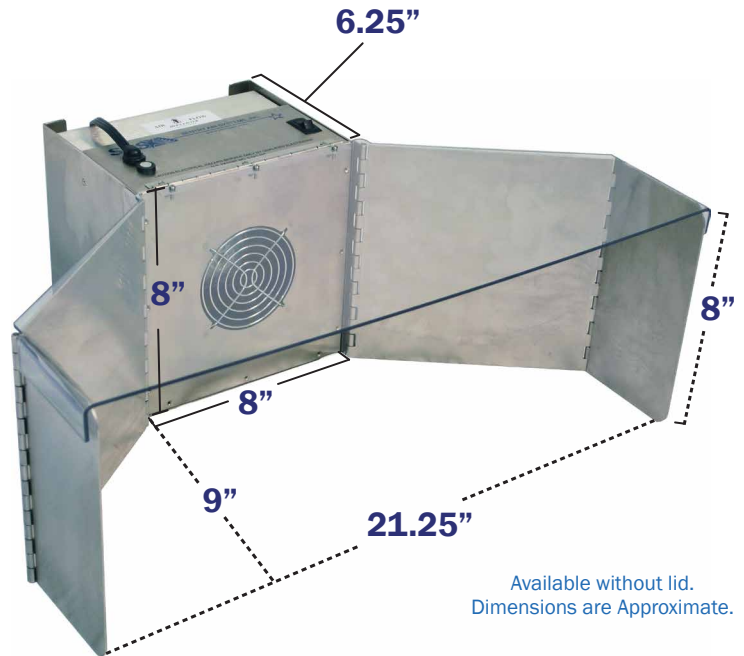

Product Features

- ESD-Safe
- Adjustable Wing Flaps
- Highly Portable and Lightweight
- Reliable, Low Maintenance Operation
- Quiet Operation
- Simple, Quick "No Tool" Filter Change
- Sturdy Construction
- Long Filter Life
- Available without Clear Acrylic Lid

The **Stainless Steel Winged Sentry with Lid** is an ESD-Safe solder fume extraction unit. It is constructed for stationary, benchtop applications that require the capture and filtration of airborne contaminants at the work surface. This unit is equipped with adjustable "wing flaps" and the transparent hinged lid completes a nearly perfect enclosure.

This system is equipped with an energy-efficient fan and high-quality filtration media: typically HEPA or ASHRAE filtration. These filters are unique in that the primary materials have been constructed from fire-retardant products. HEPA filtration is up to 99.97% efficient on particles 0.3 microns and larger, while ASHRAE filtration is up to 95% on particles 0.5 microns and larger.

The Stainless Steel Winged Sentry offers an effective, quiet & economical solution for many benchtop soldering operations which require ESD-safe fume extraction. All of Sentry Air's products are proudly manufactured in the United States and are backed by our two-year limited warranty on parts and labor.



1.800.799.4609
www.sentryair.com
sales@sentryair.com

