

Model 200 Winged Sentry

Model # SS-200-WS

Product Specifications

BASE DIMENSIONS

8.5" L x 8" W x 10.5" H

WORK AREA DIMENSIONS

9" D x 21.5" W

AIR VOLUME

Up to 100 CFM. *Varies with filter media.*

WEIGHT

Approx. 12 lbs.

CABINET MATERIAL

16 ga. Carbon Steel

ELECTRICAL

115/1/60, Approx. 0.3 Amps

220/1/50, Approx. 0.2 Amps

8' grounded power cord
with NEMA 5-15P Plug

SOUND LEVEL

Approximately 58 DBA at 3' from inlet

FILTRATION

Depending on the Application:

- HEPA [up to 99.97% efficient on particles 0.3 microns and larger]
- ASHRAE [up to 95% efficient on particles 0.5 microns and larger]
- CARBON
- SPECIALTY-BLENDED FILTER MEDIA [i.e. Acid Gas, Mercury, Aldehyde, Ammonia]

WARRANTY

Limited two-year warranty from date of shipment on defects due to materials or workmanship.

PATENT #5,843,197

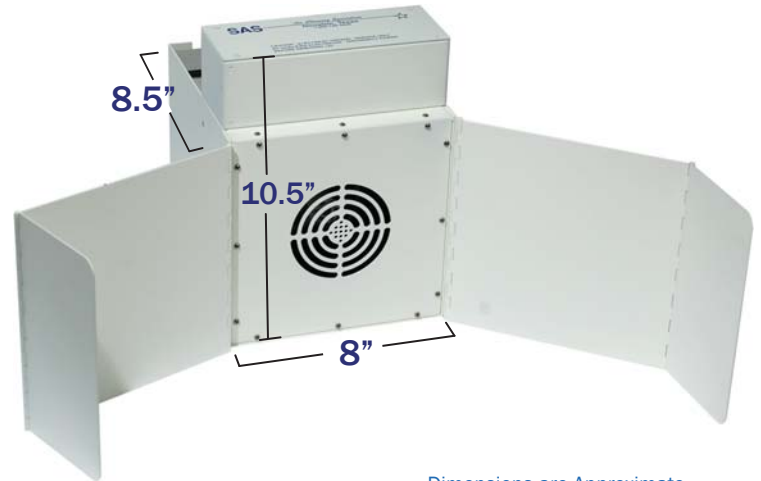

Dimensions are Approximate

Product Features

- Infinitely Adjustable "Wing Flaps"
- Highly Portable and Lightweight
- Reliable, Low Maintenance Operation
- Quiet Operation
- Simple, Quick "No Tool" Filter Change
- Long Filter Life
- Sturdy Construction
- Optional Variable Speed Controller (115V only)
- Optional Clear Acrylic Lid

The **Winged Sentry** is a compact benchtop fume extractor that offers a unique and customized design. It features adjustable "wing flaps" to assist in directing fumes towards the unit's inlet and into the filter chamber. The operator can place these wings in the most effective position for their particular application, or they can be positioned flat against the sides of the unit to conserve space.

Appropriate filtration media is installed in the Winged Sentry based on the application being performed by the operator. HEPA [up to 99.97% efficient on particles 0.3 microns and larger], ASHRAE [up to 95% efficient on particles 0.5 microns and larger], Activated Carbon, and specialty-blended media [i.e. Acid Gas, Mercury, Aldehyde, Ammonia] are the most common filters for this unit. The Winged Sentry is an optimal choice for fume extraction in applications such as soldering, capsule filling, solvent and epoxy fume, powder filling, R&D, light grinding and a variety of applications involving chemical fumes and dusts.

The **Winged Sentry** provides a highly energy-efficient, quiet and economical solution to many fume extraction needs.

An optional transparent hinged lid [SS-200-WSL] is available to further enclose the source capture area. This unit is also available with a more powerful fan and filtration system [SS-300-WS].



1.800.799.4609
www.sentryair.com
sales@sentryair.com

