

Model 300 Winged Sentry with Lid

Model # SS-300-WSL

Product Specifications

BASE DIMENSIONS

14.5" Length
13" Width
15.5" Height

WORK AREA DIMENSIONS

14" Depth
28" Width
13" Height

AIR VOLUME

Variable Speed Control Standard on 115V
350 CFM High, Down to 50 CFM Low
On/Off Toggle Switch Standard on 220V
Varies with Filter Media & Variable Speed Control

WEIGHT

Approx. 40 lbs. - 50 lbs.

CABINET MATERIAL

16 ga. Carbon Steel

LID MATERIAL

1/8" Clear Acrylic

ELECTRICAL

115/1/60, Approx. 2 Amps
220/1/50, Approx. 0.75 amps
8' grounded power cord with NEMA 5-15P Plug

SOUND LEVEL

61 to 66 dba (Blower Speed: Low to High)

FILTRATION

Depending on the Application:

- HEPA [up to 99.97% efficient on particles 0.3 microns and larger]
- ASHRAE [up to 95% efficient on particles 0.5 microns and larger]
- ACTIVATED CARBON
- SPECIALTY-BLENDED FILTER MEDIA [i.e. Acid Gas, Mercury, Aldehyde, Ammonia]

WARRANTY

Limited two-year warranty from date of shipment on defects due to materials or workmanship.

PATENT #5,843,197

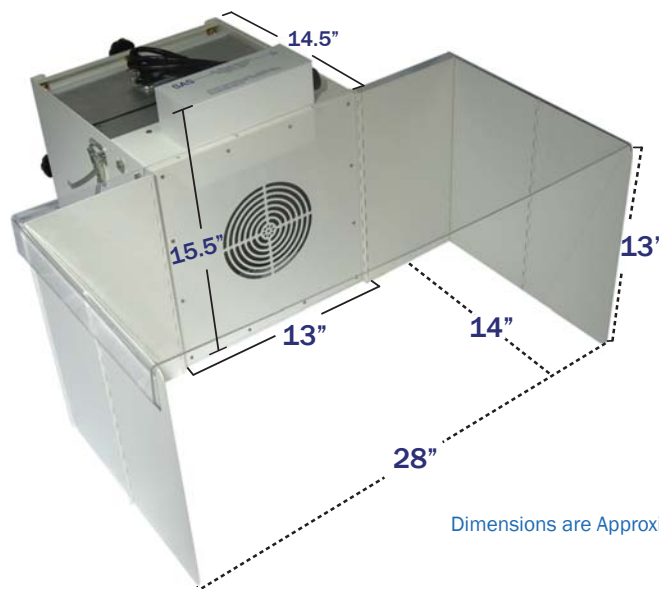

Dimensions are Approximate



Product Features

- Variable Speed Controller Included (115V only)
- Quiet Operation
- Sturdy Construction
- Clear Acrylic, Hinged Lid Included
- Simple, Quick "No Tool" Filter Change
- Long Filter Life
- Infinitely Adjustable "Wing Flaps"
- Reliable, Low Maintenance Operation
- Optional Hour Counter

The **Model 300 Winged Sentry with Lid** is a benchtop fume extraction unit that offers a unique design and horizontal airflow pattern. It features infinitely adjustable "wing flaps" to assist in directing contaminated air towards the unit's inlet and into the filter chamber while the operator works between the wings. This system offers hood-like containment without the confinements of working within an actual hood. The operator can place these wings in the most effective position for their application, or they can be placed flat against the sides of the unit to conserve space. A variable speed controller comes standard on this unit.

Typical applications performed in conjunction with the Winged Sentry are chemical fume extraction, soldering, light grinding, pharmaceutical applications like powder and capsule filling, R&D, solvent and epoxy fume control, and many other applications that involve VOC fumes and dusts.

Appropriate filtration media is selected for the Winged Sentry based on the application being performed by the operator. HEPA [up to 99.97% efficient on particles 0.3 microns and larger], ASHRAE [up to 95% efficient on particles 0.5 microns and larger], Activated Carbon, and specialty-blended filter media [i.e. Acid Gas, Mercury, Aldehyde, Ammonia] are the most common options for this unit. The Winged Sentry allows multiple filter media to be housed inside the filter chamber for applications that emit both particulates and fumes. The Winged Sentry with Lid is also available in a smaller model [Model SS-200-WSL].



1.800.799.4609
www.sentryair.com
sales@sentryair.com

