

Mounted Sentry w/ Fume Extractor Stand

Model # SS-400-MS-FES

Product Specifications

STAND DIMENSIONS

91" Total Height
Platform Base: 16" W x 22" D
Platform Top: 23" W x 19" D

STAND WEIGHT

133 lbs.

CABINET DIMENSIONS

21" L x 20" W x 19.5" H

CABINET WEIGHT

50-100 lbs. (depending on filter media installed)

CABINET MATERIAL

16 ga. carbon steel

ARM DIMENSIONS

4" dia. x 32" L fire-retardant black flex arm

AIR VOLUME

Variable Speed Control Standard on 115V
700 CFM (high), down to 50 CFM (low)
On/Off Toggle Switch Standard on 220 V

ELECTRICAL

115/1/60, 2.5 amps
220/1/50, 1.5 amps

SOUND LEVEL

Approx. 60 dBA @ 3' from inlet

FILTRATION

Depending on the Application:

- HEPA [up to 99.97% efficient on particles 0.3 microns and larger]
- ASHRAE [up to 95% efficient on particles 0.5 microns and larger]
- ACTIVATED CARBON
- SPECIALTY-BLENDED FILTER MEDIA [i.e. Acid Gas, Mercury, Aldehyde, Ammonia]

WARRANTY

Limited two-year warranty from date of shipment on defects due to materials or workmanship.

PATENT #5,843,197/#8,353,745

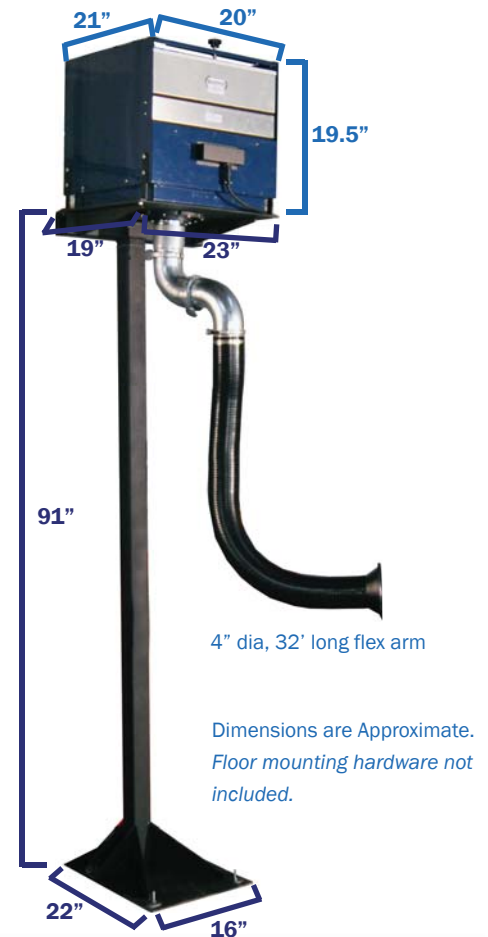

The **Model 400 Stand Mounted Sentry** fume extractor with flex arm is a complete industrial air cleaning system designed for elevated, source-capture fume extraction. This system is equipped with a powerful fan and a variety of inlet collar sizes to match your unique application and also features a variable speed controller and optional remote control.

Ideal for environments with oversized machinery, open-concept workspaces, or even smaller facilities who want to save valuable floor space, this complete system utilizes a high-strength industrial stand that secures and elevates the fume extractor up and off of the floor. The included flex arm provides a 62.5" swivel radius allowing greater flexibility within the workspace. To ensure superior hold, the stand underwent stringent structural testing with a third party engineering firm. Testing included a variety of weight loads and bend radii and the results were optimal.

Typical applications include: Welding Fume Extraction, Laser Fume Control, Chemical Fume Extraction, Pharmaceutical Powders, Particulate Control, Printing Fumes, Soldering, Solvent and Epoxy Fume Control, Fume/Vapor Source Capture, Light Grinding, and various other industrial processes.

The *Hybrid Arm* is an available upgrade.



1.800.799.4609

www.sentryair.com

sales@sentryair.com

