

## Model 400 Wall-Mounted Sky Sentry

### Model # SS-400-SKY

#### Product Specifications

##### BASE UNIT DIMENSIONS

21" Length  
 20" Width, *Not Including Mounting Brackets*  
 19.5" Height

##### ARM DIMENSIONS

4" Dia., 32" Long Fire-Retardant Flex Arm and 15" L  
 Stainless Steel Ducting (7" Dia. Round Hood)

##### CABINET MATERIAL

16 ga. Carbon Steel

##### WEIGHT

Approx. 50 lbs. - 100 lbs.  
*Varies Depending on Filter Media Installed*

##### AIR VOLUME

Variable Speed Control Standard on 115V  
 400 CFM High, Down to 50 CFM Low  
 On/Off Toggle Switch Standard on 220V

##### ELECTRICAL

115/1/60, 2.5 amps  
 220/1/50, 1.5 amps  
 8' grounded power cord with NEMA 5-15P Plug

##### SOUND LEVEL

Approx. 60 dba @ 3'

##### FILTRATION

Depending on the Application:

- HEPA [up to 99.97% efficient on particles 0.3 microns and larger]
- ASHRAE [up to 95% efficient on particles 0.5 microns and larger]
- ACTIVATED CARBON
- SPECIALTY-BLENDED FILTER MEDIA [i.e. Acid Gas, Mercury, Aldehyde, Ammonia]

##### WARRANTY

Limited two-year warranty from date of shipment on  
 defects due to materials or workmanship.  
 PATENT #5,843,197

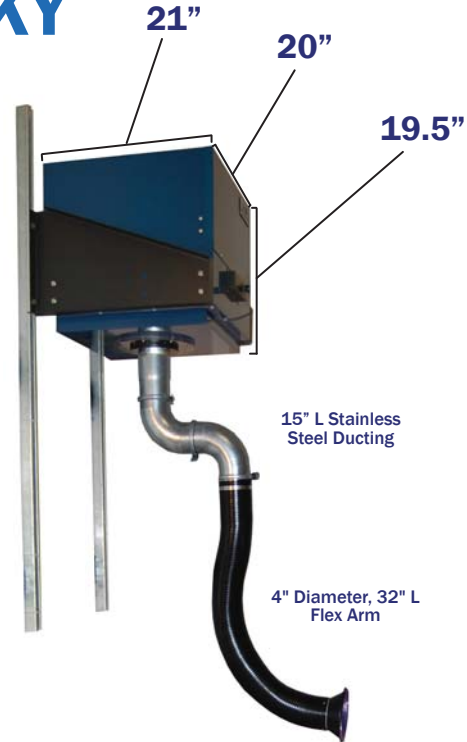

Dimensions are Approximate  
 Shown with Optional Accessories



### Product Features

- Wired Remote Speed Controller *Included (115V only)*
- Wall-Mounting Brackets *Included*
- Self-Supportive, Flexible Arm
- Reliable, Low Maintenance Operation
- Low Power Consumption
- Simple, Quick "No Tool" Filter Change
- Long Filter Life
- Optional Magnehelic Gage
- Optional Hour Counter

The **Model 400 Sky Sentry** is a wall-mounted fume extractor that features a free-hanging, self-supportive and flame-retardant flex arm that can easily be maneuvered by the operator to their desired location. In limited space environments, this unit frees up valuable benchtop and floor space while the flex arm provides a 62.5" swivel radius.

Typical applications for this system include: welding fume extraction, brazing fume control, particulate extraction, removal of organic vapors, solvent and epoxy fumes, chemical fumes, light grinding, and various other industrial processes where a wall-mounted fume extractor is needed.

Depending on the application, several filter combinations can be utilized. Typical filtration media include: HEPA [up to 99.97% efficient on particles 0.3 microns and larger], ASHRAE [up to 95% efficient on particles 0.5 microns and larger], Activated Carbon, and specialty-blended filtration media [i.e. Acid Gas, Mercury, Aldehyde, Ammonia]. Multiple filter media can be housed inside the filter chamber for applications that emit both particulates and fumes.

Two smaller models [SS-200-SKY & SS-300-SKY] and one larger model [SS-450-SKY] are also available.



1.800.799.4609  
[www.sentryair.com](http://www.sentryair.com)  
[sales@sentryair.com](mailto:sales@sentryair.com)

